

Twin Twist, Gravity Soft Serve/Yogurt Freezer

F231-AD1



- Spigot handle height meets March 15th, 2011 ADA requirements for self service locations.
- Precision controlled refrigeration system designed for quality product consistency from the first cone to the last.
- IntelliTec2™ control communicates with the operator through a multiline graphics LCD using full text instructions.
- Energy Conservation Mode (ECM) protects product from over-agitation during slow or non-draw periods.
- Compact design with a small footprint is an ideal choice for locations where space is an issue.
- Proprietary auger design gently folds mix and prevents product breakdown, producing a smoother, creamier product.
- Clear door shows visible moving product for merchandising appeal.
- Self-closing spigot eliminates waste and assures precise portion control.
- Adjustable dispense rate for optimal product output.
- Long-wearing parts offer low preventative maintenance costs.
- Built for ease of operation and cleaning.
- Twist feature allows you to serve two flavors individually or combine flavors for a unique twist.



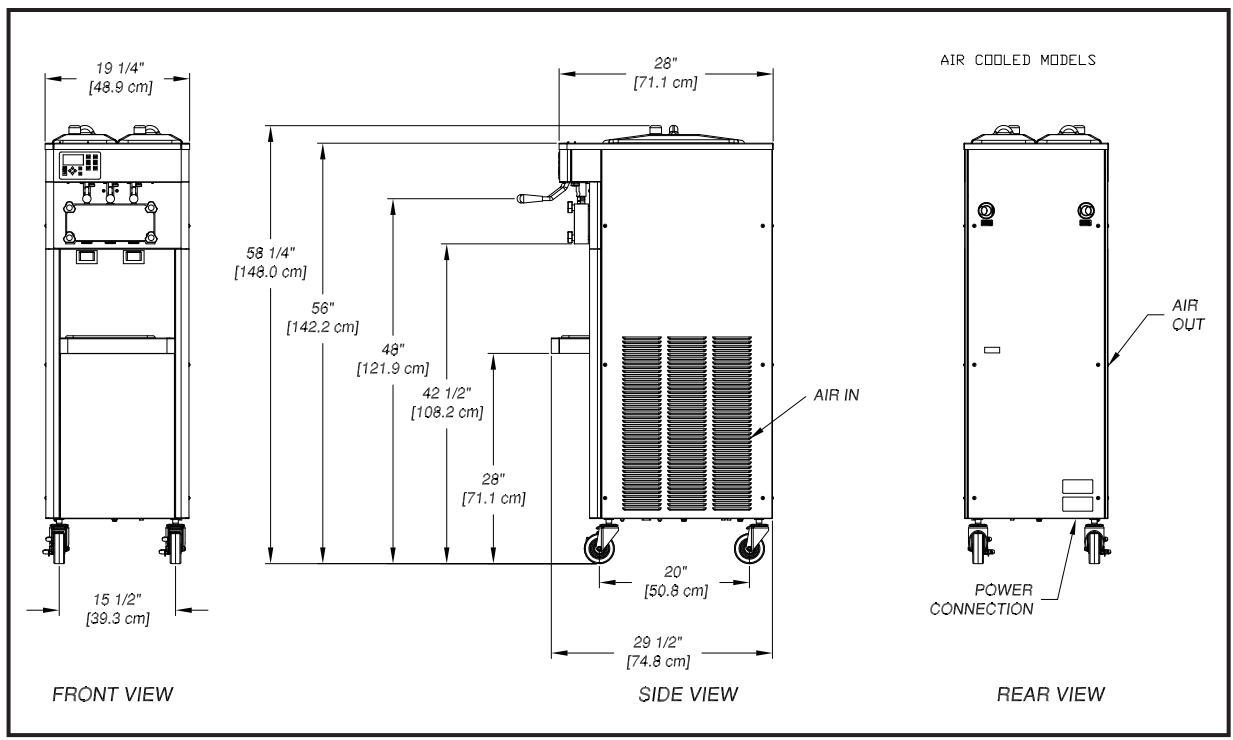

Model F231 AD1			
Dimensions	Machine	as shipped	
	width	19-1/4" (48,9 cm)	32" (81,3 cm)
	height	58-1/4" (148,0 cm)	60" (152,4 cm)
	depth	28" (71,1 cm)	39" (99,1 cm)
Weight	400 lbs (181,4 kg)	470 lbs (213,1 kg)	
* Electrical	1 Phase, 208-240 VAC, 60Hz	3 Phase, 208-240 VAC, 60Hz	
	running amps 12A	10A	
connection type	NEMA 6-20P power cord provided	NEMA L15-20P power cord provided	
International Option	1 Phase, 220-240 VAC, 50Hz		
Compressor	12,000 Btu/hr (R-404A)		
Drive Motor	Two - 3/4 hp		
Air Flow	Air cooled units require 3" (7,6 cm) air space on both sides		
Plumbing Fittings	Water cooled units require 1/2" N.P.T. water and drain fittings. Maximum water pressure of 130 psi. Minimum water flow rate of 3 GPM. Ideal EWT of 50°-70°F		
Hopper Volume	Two - 3 gallon (11,35 liters)		
Freezing Cylinder Volume	Two - 0.85 gallon (3,22 liters)		

Continuous research leads to ongoing product improvements; therefore, these specifications are subject to change without notice and should not be used as installation specifications.

* Machine requires a dedicated electrical circuit.

Distributed by:



502 Highway 67 • Kiel, WI 53042-1600
 920-894-2293 • 800-558-5807
 Fax: 920-894-7029
 E-mail: foodservice@stoelting.com
 www.stoeltingfoodservice.com

ISO 9001:2008 Registered

Certified, Listed and/or Recognized by:



STMF-102D 04/12